

NB, NBE

Single-stage end-suction pumps
50 Hz



The tables on the following pages show the complete NB, NBE product range.

The product range includes the pumps existing in WinCAPS.

The standard range has been combined on the basis of the following parameters:

- Pump housings have discharge flanges from DN 32 to DN 150.
- Pump housings and motor stools are made of electro-coated cast iron.
- Impellers are made of cast iron or bronze.
- Wear rings are made of bronze.
- Shaft seals are BAQE and GQQE.
- Motors are 50 Hz.
- NB pumps are available with 2-, 4- and 6-pole motors, NBE pumps with 2- and 4-pole motors.
- NB pumps are available with Premium range and Standard range motors.
- Motors with power rating up to and including 4 kW are available for "low voltage"; as from 2.2 kW motors are available for "high voltage".

To a great extent the pumps can be adapted to the requirements of the individual customer. For customized solutions, please contact Grundfos.

NB, NBE 50 Hz, 4-pole

Pump type 50 Hz, 4-pole	Design	P ₂ [kW]	Available as E-pump	Pressure stage PN 10	Pressure stage PN 16
NB 32-125.1/139	A	0.25			●
NB 32-125/142	A	0.37			●
NB 32-160.1/172	A	0.37			●
NB 32-160/172	A	0.55			●
NB 32-200.1/196	A	0.55			●
NB 32-200/200	A	0.75	●		●
NB 32-200/216	A	1.1	●		●
NB 40-125/116	A	0.25			●
NB 40-125/130	A	0.37			●
NB 40-125/142	A	0.55			●
NB 40-160/151	A	0.55			●
NB 40-160/166	A	0.75	●		●
NB 40-200/198	A	1.1	●		●
NB 40-200/217	A	1.5	●		●
NB 40-250/245	A	2.2	●		●
NB 40-250/260	A	3.0	●		●
NB 50-125/129	A	0.55			●
NB 50-125/142	A	0.75	●		●
NB 50-160/158	A	1.1	●		●
NB 50-160/175	A	1.5	●		●
NB 50-200/210	A	2.2	●		●
NB 50-200/219	A	3.0	●		●
NB 50-250/263	A	4.0	●		●
NB 65-125/133	A	0.75	●		●
NB 65-125/144	A	1.1	●		●
NB 65-160/149	A	1.1	●		●
NB 65-160/165	A	1.5	●		●
NB 65-160/177	A	2.2	●		●
NB 65-200/205	A	3.0	●		●
NB 65-200/219	A	4.0	●		●
NB 65-250/259	A	5.5	●		●
NB 65-315/282	A ¹⁾	7.5	●		●
NB 65-315/314	C	11.0	●		●
NB 80-160/146	A	1.5	●		●
NB 80-160/161	A	2.2	●		●
NB 80-160/175	A	3.0	●		●
NB 80-200/196	A	4.0	●		●
NB 80-200/214	A	5.5	●		●
NB 80-250/247	A ¹⁾	7.5	●		●
NB 80-250/270	C	11.0	●		●
NB 80-315/305	C	15.0	●		●
NB 80-315/320	C	18.5	●		●
NB 80-315/334	C	22.0	●		●

Pump type 50 Hz, 4-pole	Design	P ₂ [kW]	Available as E-pump	Pressure stage PN 10	Pressure stage PN 16
NB 100-200/196	A	5.5	●		●
NB 100-200/214	A ¹⁾	7.5	●		●
NB 100-250/245	C	11.0	●		●
NB 100-250/266	C	15.0	●		●
NB 100-315/295	C	18.5	●		●
NB 100-315/312	C	22.0	●		●
NB 125-250/236	C	15.0	●		●
NB 125-250/249	C	18.5	●		●
NB 125-250/262	C	22.0	●		●
NB 150-200/220	C	11.0	●	●	

¹⁾ NBE pumps are design C

NB 50 Hz, 6-pole

Pump type 50 Hz, 6-pole	Design	P ₂ [kW]	Available as E-pump	Pressure stage PN 10	Pressure stage PN 16
NB 100-200/214	A	2.2			●
NB 100-250/259	A	4.0			●
NB 100-315/326	C	7.5			●
NB 125-250/269	C	7.5			●
NB 150-200/215	A	3.0		●	

Type key

NB, NBE

Example	NB 32 -125 .1 /142 A -F -A -BAQE
Type range	
Nominal diameter of discharge port (DN)	
Nominal impeller diameter [mm]	
Reduced performance = .1	
Actual impeller diameter [mm]	
Code for pump version (the codes may be combined ¹⁾):	
A = Basic version	
B = Oversize or double-oversize motor	
C = Without motor	
D = Pump housing with feet	
E = With ATEX approval, certificate or test report	
X = Special version	
Code for pipework connection:	
F = DIN flange	
Code for materials:	
A = Basic version	
B = Bronze impeller	
S = Stainless steel impeller	
Code for mechanical shaft seal and rubber pump parts	

¹⁾ Examples of combined pump version codes:

AE = Basic version with ATEX-approval, certificate or test report

BD = Oversize motor with pump housing with feet

CE = Without motor and with certificate

Mechanical shaft seals

NB, NBE pumps are available as standard with BAQE and GQQE shaft seals. Other shaft seal variants are available on request.

Codes for mechanical shaft seal

The positions (1) - (4) cover four pieces of information about the mechanical shaft seal:

Example	(1)	(2)	(3)	(4)
Grundfos type designation				
Material, rotating seal face				
Material, stationary seat				
Material, secondary seal and other rubber and composite parts, except the wear ring				

The following table explains the positions (1), (2), (3) and (4).

Position	Type	Short description of seal
(1)	A	O-ring seal with fixed driver
	B	Rubber bellows seal
	G	Bellows seal, type B, with reduced seal faces
	D	O-ring seal, balanced
Position	Type	Material
(2) and (3)	Synthetic carbons:	
	A	Carbon, metal-impregnated (antimony (not approved for potable water))
	B	Carbon, synthetic resin-impregnated
(3)	Carbides:	
	Q	Silicon carbide
Position	Type	Material
(4)	E	EPDM
	V	FKM
	F	FXM

The mechanical shaft seal variant codes are used when stamping the nameplates for identification.

General information

Mounting

The pumps are made in three different designs:

- design A: pump housing with feet
- design B: motor with feet
- design C: pump housing and motor with feet.

See the figures below.

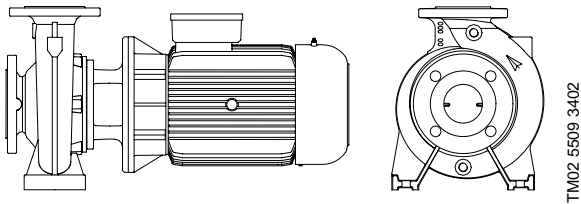

Fig. 2 NB pump design A

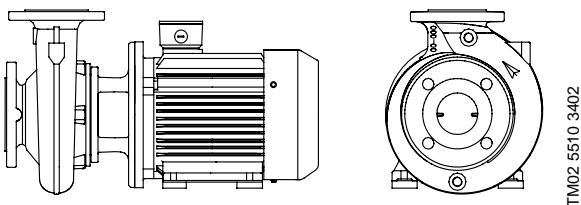

Fig. 3 NB pump design B

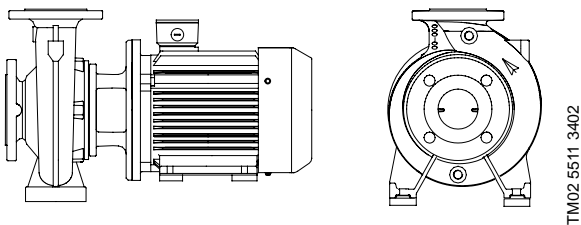
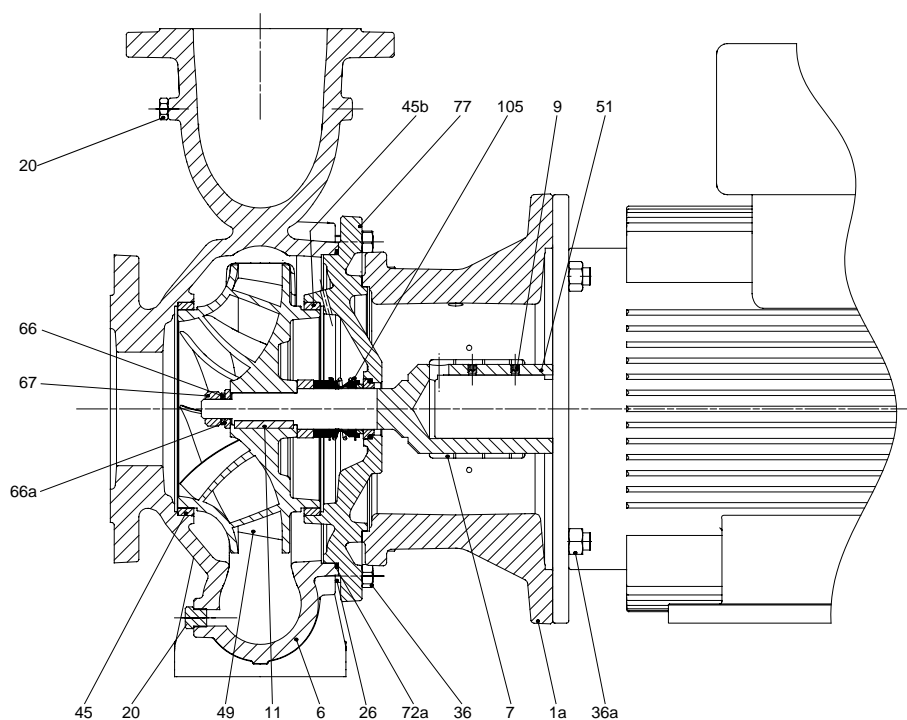

Fig. 4 NB pump design C

Sectional drawing



TM02 9142.2004

Fig. 5 Sectional drawing NB pump

Material specification

Pos.	Component	Materials	DIN W.-Nr.	AISI/ASTM
1a	Motor stool	Cast iron EN-GJL-250	EN-JL1040	A48-40B
6	Pump housing	Cast iron EN-GJL-250	EN-JL1040	A48-40B
7	Coupling guard	Stainless steel	1.4301	AISI 304
9	Set screw	Steel		
11	Parallel key	Steel		
20*	Pipe plug	Steel		
26	Staybolt	Steel		
36, 36a	Nut	Steel		
45	Wear ring	Bronze	2.1096.01	B584 - C83600
45b	Wear ring, upper	Bronze	2.1096.01	B584 - C83600
49	Impeller	Cast iron EN-GJL-200	EN-JL 1030	A48-30B
		Bronze CuSn5Zn5Pb	2.1096.01	B584 - C83600
		Stainless steel **	1.4408	
51	Shaft	Stainless steel/steel	1.4301/1.0301	
		Stainless steel/steel **	1.4401/1.0301	
66	Washer	Stainless steel	100-250	
66a	Spring washer	Stainless steel		
67	Nut	Stainless steel		
72 a	O-ring	EPDM rubber		
77	Cover	Cast iron EN-GJL-250	EN-JL1040	A48-40B
105	Shaft seal	Stainless steel	1.4301	AISI 304

* **NB, NBE:**
 32-125.1 → 80-315: R 3/8"
 100-200 → 150-200: R 1/2"

** A stainless steel impeller is combined with a stainless steel shaft, material 1.4401/1.0301.

Pump location

The pump is designed for installation in a non-aggressive and non-explosive atmosphere.

The relative air humidity must not exceed 95%.

Ambient temperature and altitude

The ambient temperature and the installation altitude are important factors for the motor life, as they affect the life of the bearings and the insulation system.

Ambient temperature must not exceed:

- +40°C for EFF 2 motors
- +60°C for EFF 1 motors.

If the ambient temperature exceeds +40°C (+60°C) or if the motor is installed more than 1000 m (3500 m) above sea level, the motor must not be fully loaded due to the low density and consequently low cooling effect of the air. In such cases, it may be necessary to use a motor with a higher output.

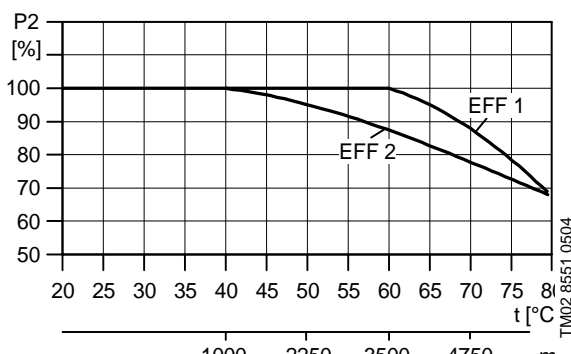

Fig. 8 Motor P2 depends on temperature/altitude

Example:

Fig. 8 shows that the load of an EFF 2-motor must be reduced to 88% when installed 3500 m above sea level.

At an ambient temperature of 70°C the load of an EFF 2-motor must be reduced to 78% of the rated output.

In such situations an oversize motor can be used.

Pumped liquids

NB pumps are suitable for pumping clean, thin, non-aggressive and non-explosive liquids, not containing any solid particles

The effect of viscosity on centrifugal pump performance

A viscous liquid affects a centrifugal pump in several ways.

- The power consumption will be increased, i. e. a larger motor is required.
- Head, flow rate and pump efficiency will be reduced.

The effect of high density on centrifugal pump performance

A high density liquid only affects the power consumption of a centrifugal pump.

- The head, flow rate and pump efficiency will remain unchanged.
- The power consumption will increase at a ratio corresponding to the increase in density. A liquid with a specific gravity of 1.2 will thus require a 20% larger power input.
- An oversize motor will often be required.

WinCAPS can help you select the right pump for liquids with viscosity/density different from those of water.

Liquid temperatures

The NB, NBE pump range covers the temperature range from -25°C (~-13°F) to +140°C (~+284°F). The permissible liquid temperature depends on the mechanical shaft seal type and pump type. See also table below.

Be aware that the maximum liquid temperature limits stated by Grundfos may be overruled by local regulations and various laws.

The maximum liquid temperature is stamped on the nameplate.

Relationship between mechanical shaft seals and temperature

Mechanical shaft seal	Operating temperature	Maximum operating pressure [bar]
BAQE	0°C to +120°C	16 bar
GQQE	-25°C to +90°C	16 bar
BQBE	0°C to +140°C	16 bar
DAQF	0°C to +140°C	16 bar
BQQV ¹⁾	0°C to +90°C	16 bar
BBQE	0°C to +120°C	16 bar
BAQV ¹⁾	0°C to +90°C	16 bar
GQQV ¹⁾	-20°C to +90°C	16 bar
BQQE	-25°C to +90°C	16 bar
AQQE	0°C to +90°C	16 bar
AQQV ¹⁾	0°C to +90°C	16 bar
AQAE	0°C to +120°C	16 bar
AQAV ¹⁾	0°C to +90°C	16 bar

BAQE and GQQE are standard shaft seals.

The remaining shaft seal combinations in the list are available for custom built pumps.

1) The maximum temperature for FKM rubber is 80°C (~176°F) in liquids containing water. For liquids not containing water, such as pure oil, the seal faces of the mechanical shaft seal are the temperature limiting factor.

Performance curves

NB 80-160
4-pole

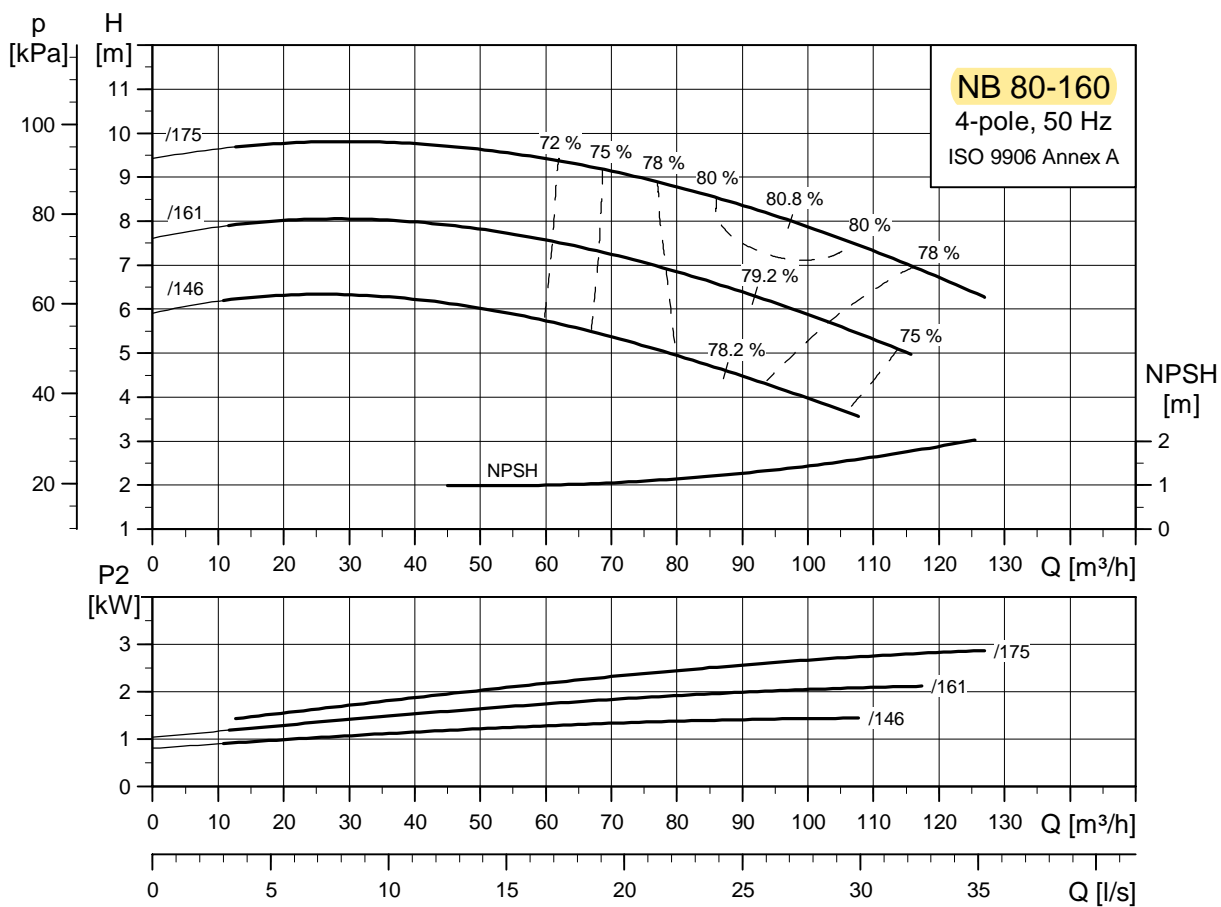

TM03 3292 0606

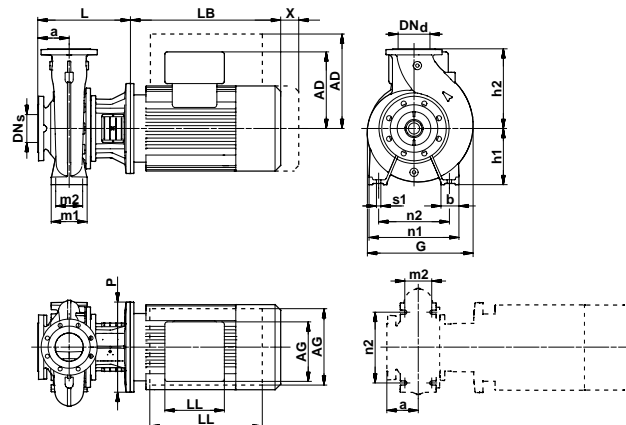

TM02 9206 2104

NB		NB 80-160/146	NB 80-160/161	NB 80-160/175
NBE		NBE 80-160/146	NBE 80-160/161	NBE 80-160/175
IEC size	NB ¹⁾	MG 90LA-C/MG 90LC-D MG 100LB-C/MG 100LB-D MG 112MA-C/MG 100LC-D		
	NBE	MGE 90LA	MGE 100LB	MGE 112MA
P2	[kW]	1.5	2.2	3.0
Design		A	A	A
PN	[bar]	PN 16	PN 16	PN 16
DN _s	[mm]	100	100	100
DN _d	[mm]	80	80	80
a	[mm]	125	125	125
b	[mm]	65	65	65
B ²⁾	[mm]	-	-	-
LB ²⁾	[mm]	281/321/321	335/335/335	335/335/335
p ²⁾	[mm]	200/200/198	250/250/250	250/250/250
C ²⁾	[mm]	-	-	-
G	[mm]	342	342	342
H	[mm]	-	-	-
h1	[mm]	180	180	180
h2	[mm]	225	225	225
L	[mm]	271	299	299
m1	[mm]	125	125	125
m2	[mm]	95	95	95
n1	[mm]	320	320	320
n2	[mm]	250	250	250
s1	[mm]	M12	M12	M12
A	[mm]	-	-	-
AA ²⁾	[mm]	-	-	-
AB ²⁾	[mm]	-	-	-
K ²⁾	[mm]	-	-	-
AD ²⁾	[mm]	110/110/167	120/120/177	120/120/177
AG ²⁾	[mm]	81/81/264	162/162/264	162/162/264
LL ²⁾	[mm]	81/81/260	103/103/260	103/103/260
X	Motor only	[mm]	50	60
	Motor and motor stool	[mm]	140	140
NB ⁷⁾	Standard motor range	56/63/0.306	64/72/0.306	68/76/0.306
	Premium motor range	61/68/0.306	68/76/0.306	70/78/0.306
NBE ⁷⁾	E-motor range	62/69/0.306	69/78/0.498	78/87/0.498

¹⁾ Frame size of standard range motor/premium range motor.

²⁾ Dimension of pump with standard range motor/premium range motor/E-motor range.

⁷⁾ Net weight [kg]/gross weight [kg]/shipping volume [m³].

96495310 0406	GB
Repl. 96495310 1005	

Subject to alterations.